

FEATURES

- All SS measuring system
- Socket-case, direct welded
- Dry / liquid filled
- CE marking

APPLICATION

- Oil & Gas applications
- Corrosive environments
- Liquid & gaseous mediums
- Nuclear power plants

DIN Style Case & Ring



STANDARD PARAMETERS

Accuracy	: CL 1.0
Ambient temperature	: -40...+65°C (without dampening liquid)
	: -20...+65°C (with dampening liquid)
Service temperature	: 300°C max.
Pressure limits	: Steady pressure up to FS value
	: Fluctuating pressure up to 90% of FS value
	: Short time 1.3 x FS value for range up to 100 bar
	: Short time 1.15 x FS value for range above 100 bar
Weld joints	: TIG argon arc welding

MATERIAL OF CONSTRUCTION

Sensing element	: Bourdon Tube (<100 bar : C - type , > 100 bar : Helical)
Case & Ring material	: AISI 304 SS (Bayonet type), DIN style
Bourdon tube & Shank	: AISI 316L SS (Shank welded directly to case)
Movement mechanism	: AISI 304 SS
Dial	: Aluminum, black graduation on white background
Pointer	: Micro-zero adjustable, aluminum, black powder coated
Gaskets, Blow off disc & filling plug	: Neoprene
Window	: Shatterproof safety glass

STANDARD SPECIFICATIONS

Dial size	: DN63 / DN100 / DN150
Range	: -1...0...1,600 bar
Mounting pattern	: Direct, Bottom connection
Process connection	: 1/2" NPT (M)
Ingress protection	: IP 65
Execution	: Dry but fillable, glycerin

STANDARD SPECIFICATIONS : DAMPENING LIQUID FILLED, GLYCERIN

Window	: Safety glass
Dampening liquid	: Glycerin 99.7% [Service temperature up to 65°C]

TEMPERATURE EFFECT

When temperature of the measuring system deviates from reference temperature (+20°C) max error $\pm 0.4\%$ / 10K of true scale value.

REFERENCE

EN 837-1, PED 97/23/EC

DIMENSIONAL DRAWING

Type B0

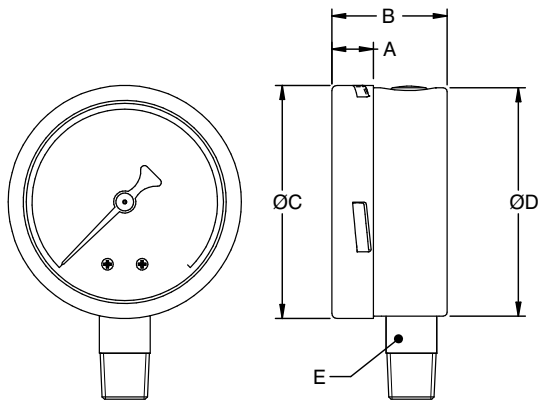

DN	A	B	ØC	ØD	E	Weight (grams)
63	12	32	64	61.7	SQ.14	190

Type B0

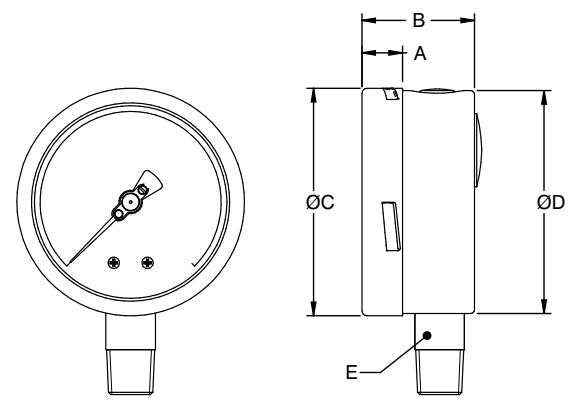

DN	A	B	ØC	ØD	E	Weight (grams)
100	16.5	50	101	99	SQ.22	491
150	17	51	162	159	SQ.22	890

Type B1

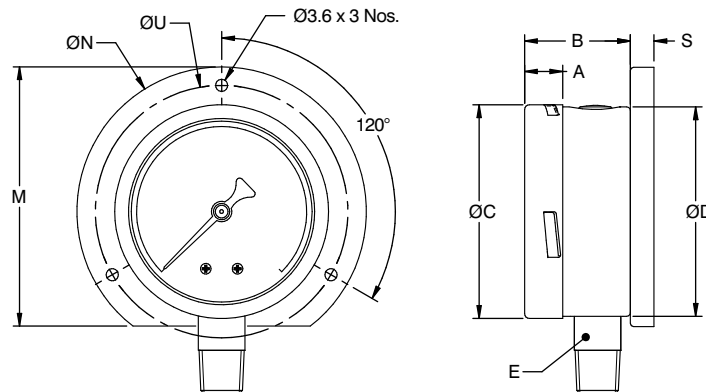

DN	A	B	ØC	ØD	E	M	ØN	S	ØU	Weight (grams)
63	12	32	64	61.7	SQ.14	80	86	7	75	240

Type B1

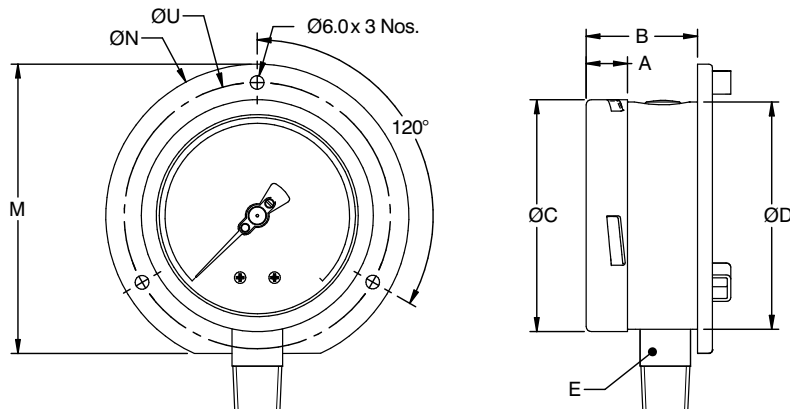

DN	A	B	ØC	ØD	E	M	ØN	ØU	Weight (grams)
100	16.5	54	101	99	SQ.22	126	132	116	598
150	17	55	162	159	SQ.22	188	196	178	1070

DIMENSIONAL DRAWING

Type R0

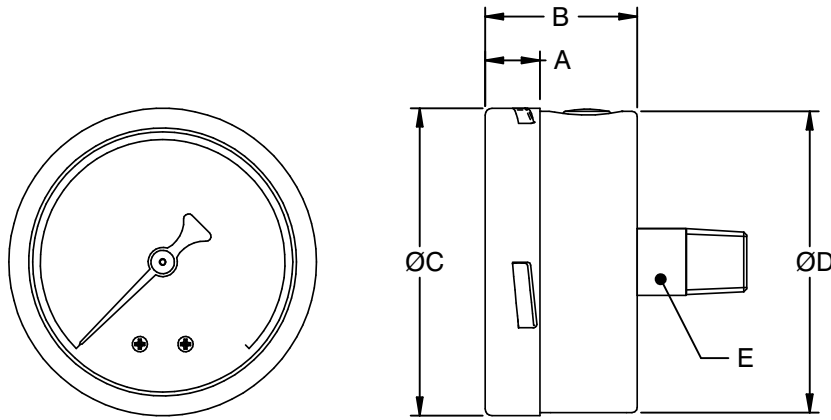

DN	A	B	ØC	ØD	E	Weight (grams)
63	12	32	64	61.7	SQ.14	190

Type L0

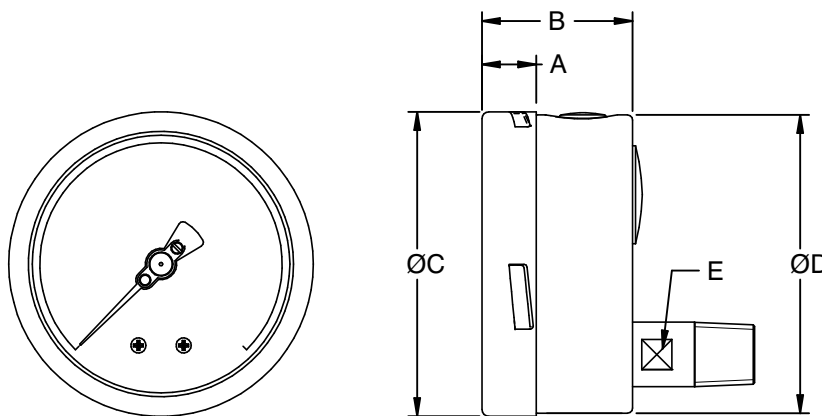

DN	A	B	ØC	ØD	E	Weight (grams)
100	16.5	50	101	99	A/F-18	491
150	17	51	162	159	A/F-18	890

ORDERING CODES

1. DIAL SIZE

25	63 mm / 2.5"
04	100 mm / 4"
06	150 mm / 6"

04

2. RANGE

XXX	Refer "Range Table"
------------	---------------------

XXX

3. MOUNTING PATTERN

B0	Direct, Bottom connection
B1	Wall/Surface/Projection mounting, Bottom connection
R0	Centre, Back connection
L0	Lower, Back connection
L1	Panel/Front flange mounting, Lower Back connection
L2	Panel/bracket mounting, Lower Back connection

B0

4. PROCESS CONNECTION

12B	1/4" BSP (M)
12N	1/4" NPT (M)
13B	3/8" BSP (M)
14B	1/2" BSP (M)
14M	M20 X 1.5 mm (M)
14N	1/2" NPT (M)

14N

5. INGRESS PROTECTION

ER	IP 65
ES	IP 66
ET	IP 67

ER

6. EXECUTION

EA	Dry ⁸
EB	Dry but fillable, glycerine
EC	Dry but fillable, silicon oil ²
EG	Dampening liquid filled, glycerine
EH	Dampening liquid filled, silicon oil ²

EA

7. OTHER OPTIONS

BA	Case & Ring in AISI 316 SS (B0)
BB	Case & Ring in AISI 316 SS (B1)
BG	Case & Ring in AISI 316 SS (R0)
BK	Case & Ring in AISI 316 SS (L0)
BL	Case & Ring in AISI 316 SS (L1)
BM	Case & Ring in AISI 316 SS (L2)
EM	Dampening screw, Monel
EN	Dampening screw, AISI 316 SS
EX	Internal overload stop
EY	Internal vacuum stop
EZ	Pointer stop on dial
G9	Dial with Freon temperature scales
GB	Plexi glass
GD	Toughened glass
GL	AISI 316 SS movement
GM	Dampened movement
GW	Maximum Reading pointer ⁴
GX	Knife edge pointer
MN	Monel wetted parts
N9	Dial with Ammonia temperature scale
OP	Overrange protection 1.5xFS
P8	Epoxy coating (Case & Ring)
R9	Receiver gauge ⁵
RA	Rubber parts, Viton
RN	Rubber parts, NBR
RW	Vent plug, ON-OFF type
TA	5 - point calibration certificate
TC	Material test certificate 3.1
TE	CE certificate
TI	IBR certification
TL	Helium leak testing
TM	Material test certificate 2.2
TN	Tested to NACE standards
TO	Certification for Oxygen service
TP	Performance test
TT	C.C. with NABL traceability
XA	Accuracy CL 0.5 / CL 0.6 of FS
XF	SS tag plate, AISI 304 SS
XG	SS tag plate, AISI 316 SS
XK	Electro polished (Case & Ring)
XN	Anti-parallax mirror band
XR	Custom designed dial
XT	Dial tag marking

XX

Ordering Example : P104-04-XXX-B0-14N-ER-EA

NOTES

1. For other connections, please contact factory.
2. Rubber parts shall be in Viton.
3. Available in DN100 & DN150 only.
4. Available in dry version only with accuracy CL 1.0 or above.
5. Please specify the second scale required.
6. For options applicable to dial size code 25, please refer model P103.
7. C.C = Calibration Certificate
8. Available with Ingress Protection IP 54 (Dust Proof) only.