

## FEATURES

- Economical and light weight
- All welded construction
- Laser welded diaphragm

## APPLICATION

- Separation systems
- Isolation applications
- Viscous & corrosive media
- High-pressure applications
- High vibration application

### Heavy Duty Mini Seal



### STANDARD SPECIFICATIONS

Range type	: -1...0 bar & 0...2.5 bar / 4...70 bar / 100...250 bar / 280...600 bar
Chamber material	: AISI 316 SS
Diaphragm	: AISI 316L SS
Instrument connection	: 1/2" NPT (F)
Sealing fluid	: Silicon DC 200 (-40...205°C)
Process connection	: 1/2"NPT (M)
Assembly	: Direct
Capillary	: Optional
Armour	: Optional
Remote mounting length	: Optional

### DIMENSIONAL DRAWING

Type S11

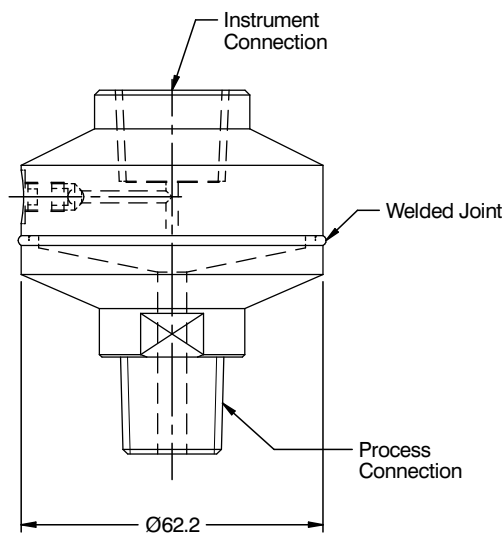

Type S12

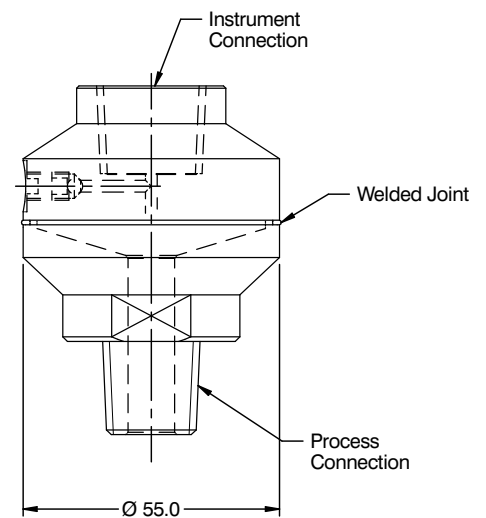

All dimensions are in mm.

## DIMENSIONAL DRAWING

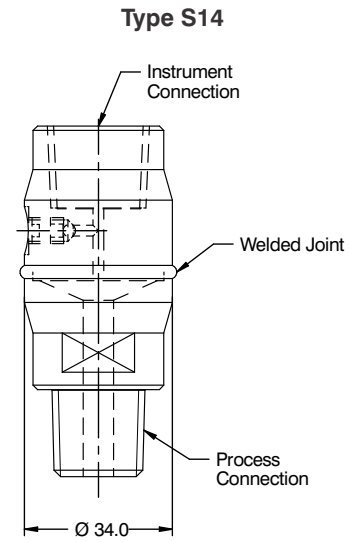
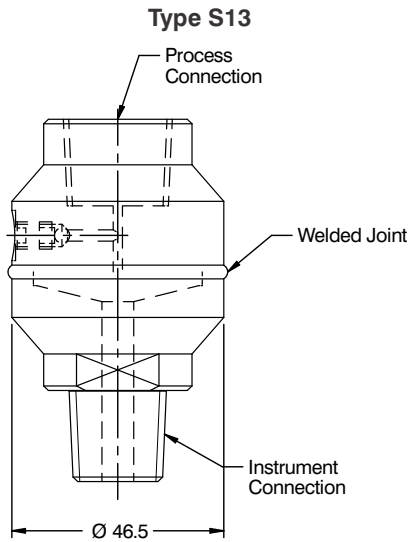

All dimensions are in mm.

## ORDERING CODES

### 1. RANGE TYPE

<b>S11</b>	-1...0 bar & 0...2.5 bar
<b>S12</b>	4...70 bar
<b>S13</b>	100...250 bar
<b>S14</b>	280...600 bar

S11

### 2. CHAMBER MATERIAL

<b>LF</b>	AISI 316 SS	<b>LG</b>	AISI 316L SS
<b>NM</b>	Monel 400	<b>NO</b>	Hastelloy C-276

LC

### 3. DIAPHRAGM MATERIAL

<b>DG</b>	AISI 316L SS	<b>DO</b>	Hastelloy C-276
<b>DV</b>	Titanium	<b>D8</b>	Silver coated
<b>DM</b>	Monel 400	<b>DQ</b>	Inconel 600
<b>DW</b>	Tantalum		

DG

### 4. INSTRUMENT CONNECTION

<b>03B</b>	3/8" BSP (F)	<b>04N</b>	1/2" NPT (F)
<b>02B</b>	1/4" BSP (F)	<b>04B</b>	1/2" BSP (F)
<b>02N</b>	1/4" NPT (F)		

04N

### 5. SEALING FLUID

<b>OA</b>	Silicon DC 200 [-40°C to 205°C]
<b>OF</b>	Food grade oil [-20°C to 140°C]
<b>OG</b>	Glycerine [10°C to 150°C]
<b>OI</b>	Syltherm 800 [-40°C to 315°C]
<b>OL</b>	Silicon DC 710 [7°C to 371°C]

0A

### 6. PROCESS CONNECTION

<b>12B</b>	1/4" BSP (M)	<b>13B</b>	3/8" BSP (M)
<b>14B</b>	1/2" BSP (M)	<b>12N</b>	1/4" NPT (M)
<b>14N</b>	1/2" NPT (M)	<b>14M</b>	M20 x 1.5 (M)
<b>02N</b>	1/4" NPT (F)	<b>04N</b>	1/2" NPT (F)
<b>02B</b>	1/4" BSP (F)	<b>04B</b>	1/2" BSP (F)
<b>03B</b>	3/8" BSP (F)		

14N

### 7. ASSEMBLY

<b>B8</b>	Direct
<b>B9</b>	Remote (capillary)

B8

### 8. CAPILLARY

<b>OU</b>	AISI 304 SS	<b>OV</b>	AISI 316 SS
-----------	-------------	-----------	-------------

XX

### 9. ARMOUR

<b>OX</b>	AISI 304 SS	<b>OY</b>	AISI 316 SS
<b>OZ</b>	PVC (Ambient max. 60°C)		

XX

### 10. REMOTE MOUNTING LENGTH

<b>XXXX</b>	1000 mm up to 4000 mm
-------------	-----------------------

XXXX

### 11. OTHER OPTIONS

<b>XZ</b>	Dry seal
<b>HL</b>	Helium leak test
<b>TM</b>	Material test certificate 2.2
<b>TC</b>	Material test certificate 3.1
<b>E8</b>	Weld constructed bottom chamber (Eco version)

XX

**Ordering Example : D103-S11-LC-DG-04N-OA-14N-B8**

#### NOTES:

- Other sealing liquids are available, contact factory for further details.
- Remote mounting applicable in range type S11, S12 & S13.
- All metal diaphragms are laser welded to the Top Chamber.