

FEATURES

- Inert gas filled expansion
- Filled versions
- Bi-metal compensation

APPLICATION

- Liquid & gaseous mediums
- Corrosive environments
- Oil & Gas applications
- Chemical & Petrochemical

Inert gas filled system



STANDARD PARAMETERS

Accuracy	: CL 1.0 (Class 1)
Ambient temperature	: 0...40°C max at case
Storage & Transport temperature	: -50...+70°C without liquid dampening
	: -20...+60°C with liquid dampening
Over range limits	: 110% full scale
Stem pressure rating	: 25 bar (Without thermowell)
Weld joints	: TIG argon arc welding

MATERIAL OF CONSTRUCTION

Sensing element	: Inert Gas Filled sensor bulb
Case & Ring material	: AISI 304 SS
Stem & Process connection material	: AISI 316 SS
Dial	: Aluminum, black graduation on white background
Pointer	: Micrometer zero adjustable, aluminum, black powder coated
Gaskets	: Neoprene
Window	: Sheet glass

STANDARD SPECIFICATIONS

Dial size	: DN100
Range	: 0...100°C
Mounting pattern	: Direct Bottom connection
Stem size	: 6.0 mm
Ingress protection	: IP 65
Stem length	: 300 mm
Assembly	: Direct
Process connection type	: Adjustable connection
Process connection	: 1/2" NPT (M)

STANDARD SPECIFICATIONS : DAMPENING LIQUID FILLED, GLYCERIN

Gaskets & Filling plugs	: Neoprene
Dampening liquids	: Glycerin 99.7% (-20°C to 65°C) [Up to range 100°C]
Window	: Shatterproof safety glass

STANDARD SPECIFICATIONS : DAMPENING LIQUID FILLED, SILICON

Gaskets & Filling plugs	: NBR
Dampening liquids	: Silicon oil [Up to range 200°C]
Window	: Shatterproof safety glass

REFERENCE

EN 13190

DIMENSIONAL DRAWING

Mounting Pattern: B0

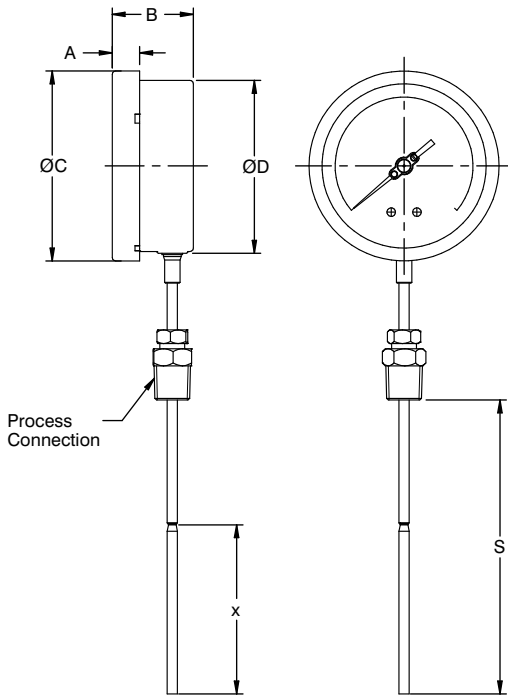

DN	A	B	ØC	ØD	S	X
100	12	48	111	100	*	**
125	15	48	129	118.5	*	**
150	15	48	161	149	*	**
250	18.5	50	263	250	*	**

* As per customer requirement.
 ** Refer technical sheet - Temperature Gauges.

Mounting Pattern: B1

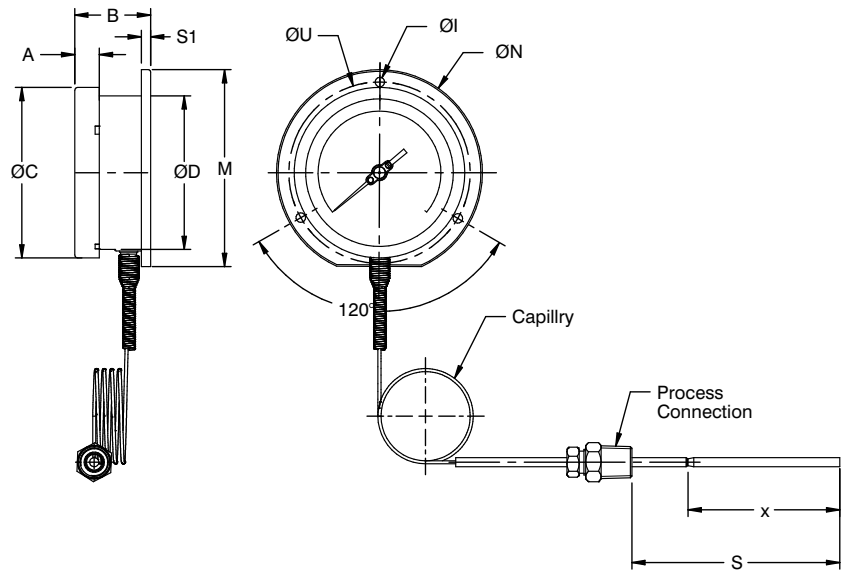

DN	A	B	ØC	ØD	ØI	ØN	M	S1	ØU	S	X
100	12	52	111	100	6	134	128	6	118	*	**
125	15	50	129	118.5	6	150	143.5	4	137	*	**
150	15	52	161	149	6	186	172.4	6	168	*	**
250	18.5	51.5	263	250	7	290	286.5	1.5	276	*	**

* As per customer requirement.
 ** Refer technical sheet - Temperature Gauges.

Mounting Pattern: B2

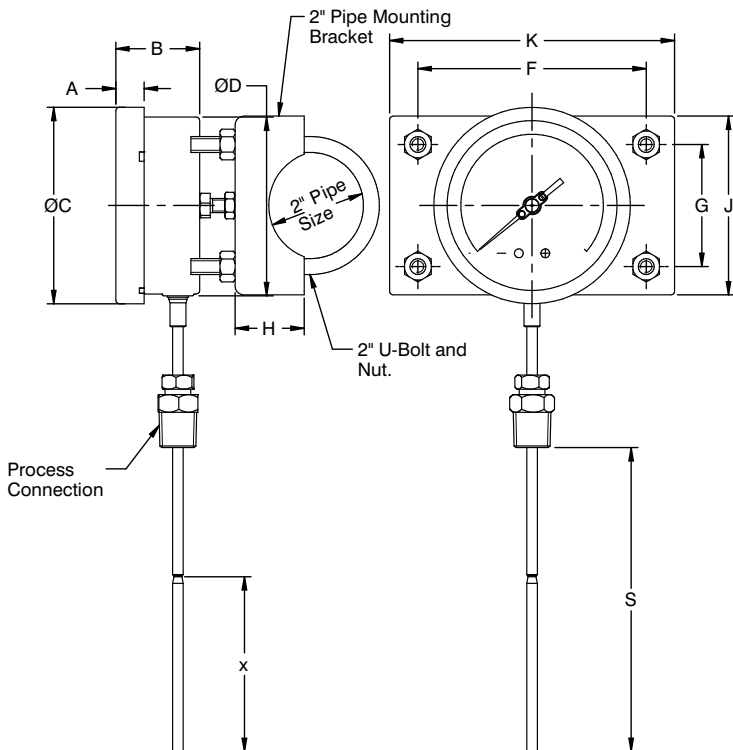

DN	A	B	ØC	ØD	S	X	F	G	H	J	K
100	12	48	111	100	*	**	129	69	39	101	161
125	15	48	129	118.5	*	**	129	69	39	101	161
150	15	48	161	149	*	**	129	69	39	101	161
250	18.5	50	263	250	*	**	129	69	39	101	161

* As per customer requirement.
 ** Refer technical sheet - Temperature Gauges.

All dimensions are in mm.

DIMENSIONAL DRAWING

Mounting Pattern: B6

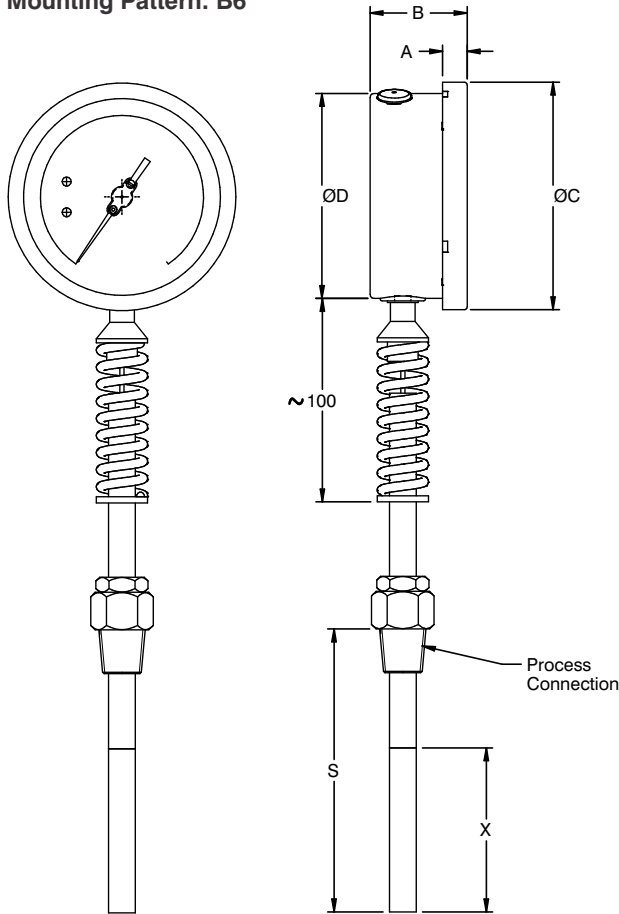

DN	A	B	ØC	ØD	S	X
100	12	48	111	100	*	**
125	15	48	129	118.5	*	**
150	15	48	161	149	*	**
250	18.5	50	263	250	*	**

* As per customer requirement.
 ** Refer technical sheet - Temperature Gauges.

Mounting Pattern: B9

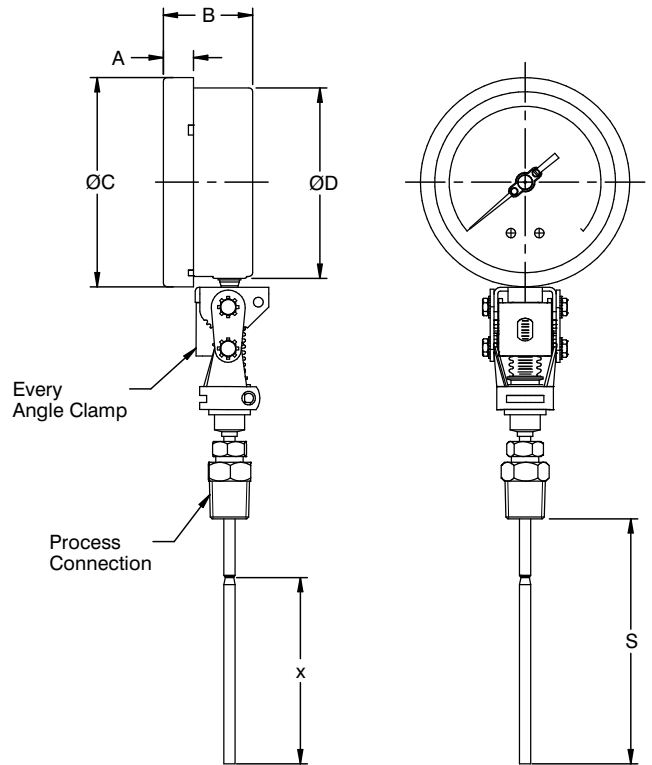

DN	A	B	ØC	ØD	S	X
100	12	48	111	100	*	**
125	15	48	129	118.5	*	**
150	15	48	161	149	*	**
250	18.5	50	263	250	*	**

* As per customer requirement.
 ** Refer technical sheet - Temperature Gauges.

Mounting Pattern: R0

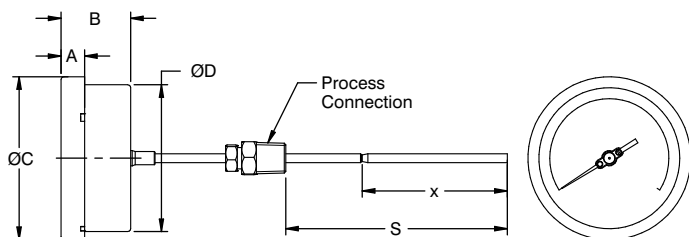

DN	A	B	ØC	ØD	S	X
100	12	48	111	100	*	**
125	15	48	129	118.5	*	**
150	15	48	161	149	*	**
250	18.5	50	263	250	*	**

* As per customer requirement.
 ** Refer technical sheet - Temperature Gauges.

Mounting Pattern: R1

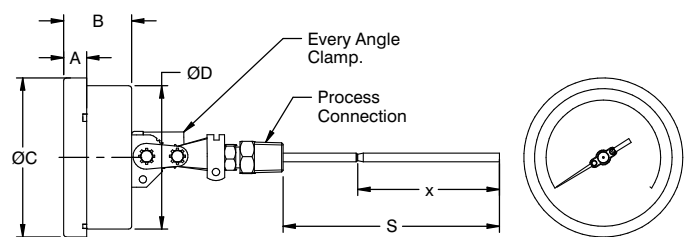

DN	A	B	ØC	ØD	S	X
100	12	48	111	100	*	**
125	15	48	129	118.5	*	**
150	15	48	161	149	*	**
250	18.5	50	263	250	*	**

* As per customer requirement.
 ** Refer technical sheet - Temperature Gauges.

All dimensions are in mm.

DIMENSIONAL DRAWING

Mounting Pattern: L0

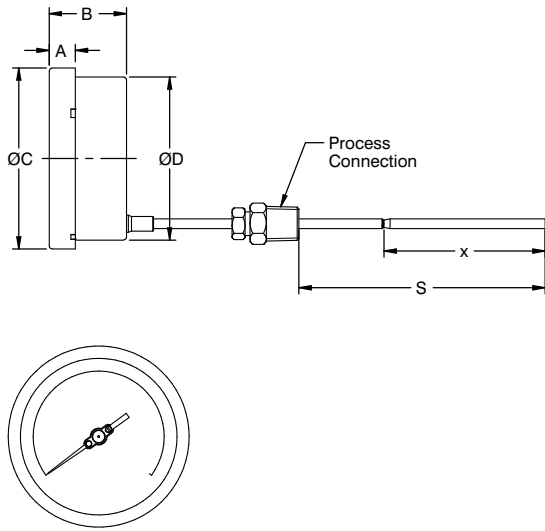

DN	A	B	ØC	ØD	S	X
100	12	48	111	100	*	**
125	15	48	129	118.5	*	**
150	15	48	161	149	*	**
250	18.5	50	263	250	*	**

* As per customer requirement.
 ** Refer technical sheet - Temperature Gauges.

Mounting Pattern: L1

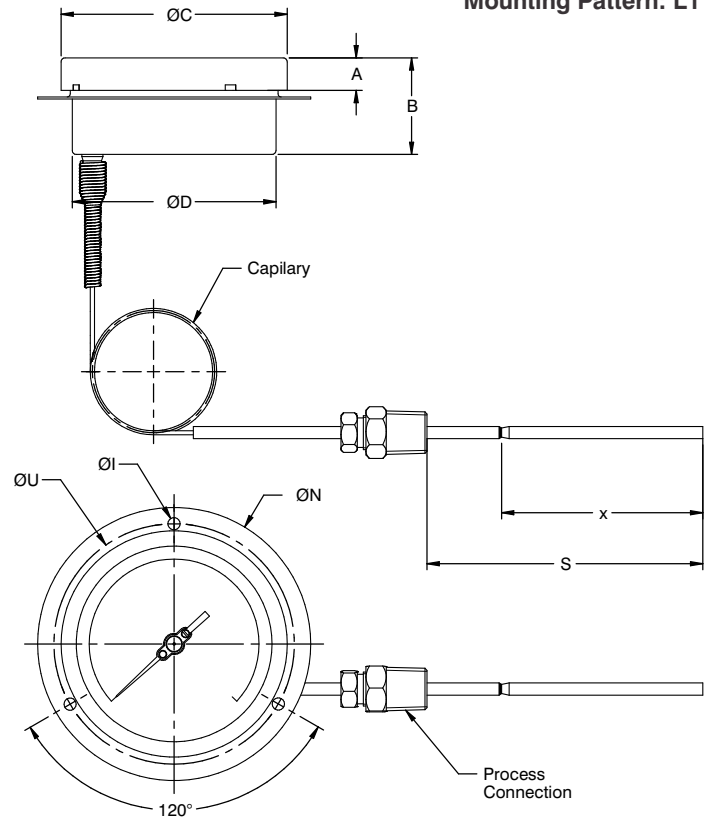

DN	A	B	ØC	ØD	ØI	ØN	ØU	S	X
100	12	48	111	100	6	134	118	*	**
125	15	48	129	118.5	6	150	137	*	**
150	15	48	161	149	6	186	168	*	**
250	18.5	50	263	250	7	290	276	*	**

* As per customer requirement.
 ** Refer technical sheet - Temperature Gauges.

Mounting Pattern: R0

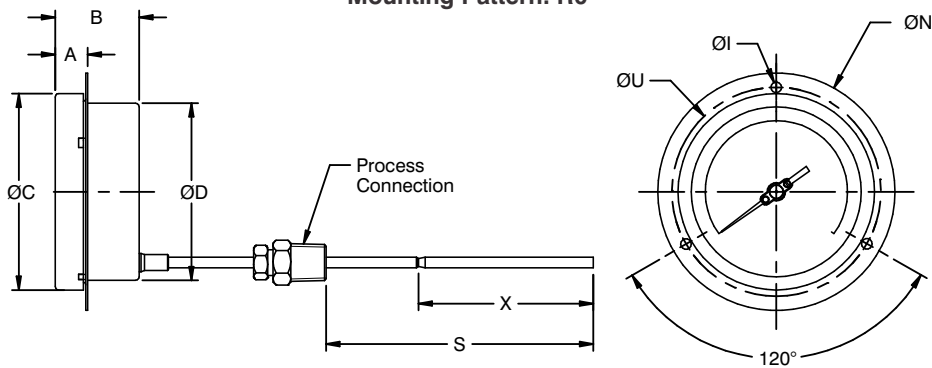

DN	A	B	ØC	ØD	S	X	F	G	H	J	K
100	12	48	111	100	*	**	129	69	39	101	161
125	15	48	129	118.5	*	**	129	69	39	101	161
150	15	48	161	149	*	**	129	69	39	101	161
250	18.5	50	263	250	*	**	129	69	39	101	161

* As per customer requirement.
 ** Refer technical sheet - Temperature Gauges.

All dimensions are in mm.

DIMENSIONAL DRAWING

Mounting Pattern: L2

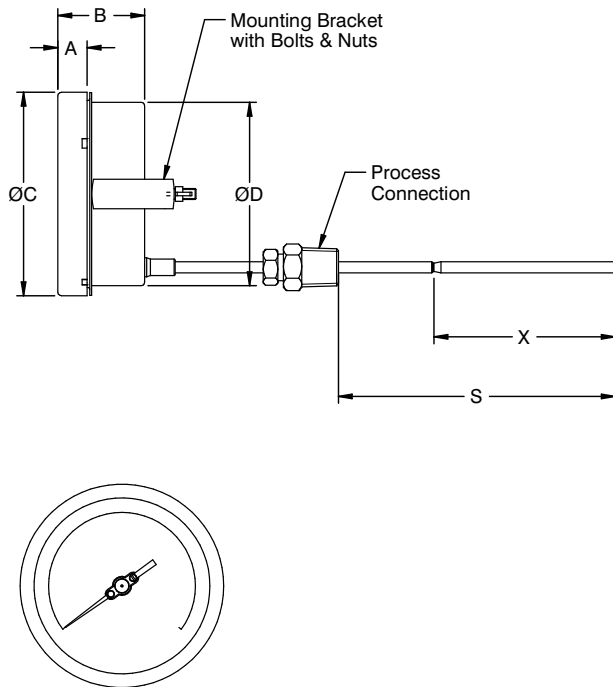

Mounting Pattern: L2

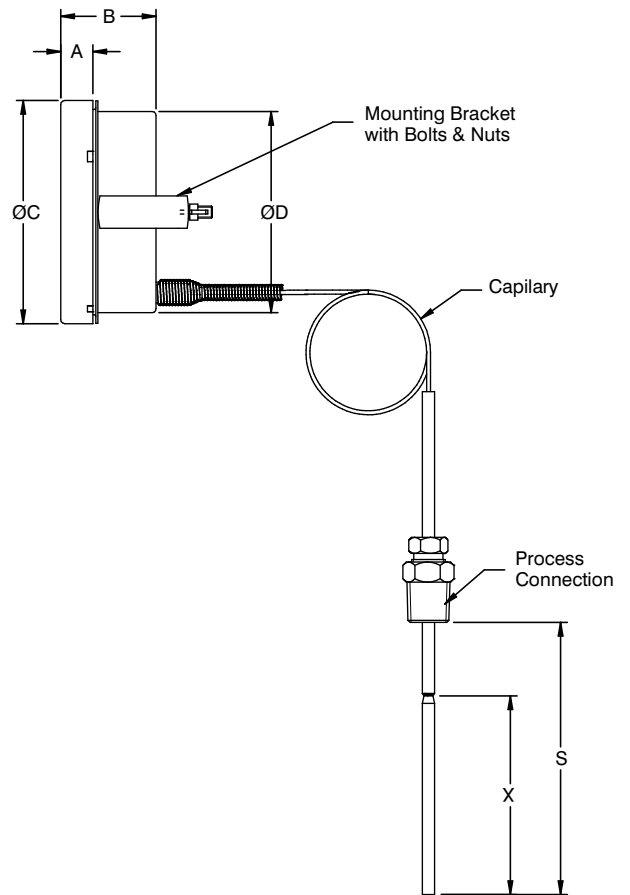

DN	A	B	ØC	ØD	J	K	V	S	X
100	12	48	111	100	72	16	108	*	**
125	15	48	129	118.5	75	15	125	*	**
150	15	48	161	149	106.5	16	158.5	*	**
250	18.5	50	263	250	180	30	270	*	**

DN	A	B	ØC	ØD	J	K	V	S	X
100	12	48	111	100	72	16	108	*	**
125	15	48	129	118.5	75	15	125	*	**
150	15	48	161	149	106.5	16	158.5	*	**
250	18.5	50	263	250	180	30	270	*	**

* As per customer requirement.
 ** Refer technical sheet - Temperature Gauges.

* As per customer requirement.
 ** Refer technical sheet - Temperature Gauges.

All dimensions are in mm.

RANGE TABLE

RANGE	" °C "	RANGE	" °C "	RANGE	" °C "
-20...+40	C01	-50...+100	C11	0...250	C21
-20...+60	C02	-100...+60	C12	0...300	C22
-20...+80	C03	0...50	C13	0...400	C23
-20...+100	C04	0...60	C14	0...500	C24
-20...+120	C05	0...80	C15	0...600	C25
-20...+180	C06	0...100	C16	0...650	C26
-30...+50	C07	0...120	C17	50...650	C27
-30...+70	C08	0...150	C18	100...600	C28
-40...+40	C09	0...160	C19	100...700	C29
-40...+60	C10	0...200	C20		

NOTES

- For other ranges, please contact factory.
- Equivalent scales available in °F, °C/°F, °F/°C.

ORDERING CODES

1. DIAL SIZE

04	100 mm / 4"
05	125 mm / 4½"
06	150 mm / 6"
10	250 mm / 10"

04

2. RANGE

XXX	Refer "Range Table"
------------	---------------------

C16

3. MOUNTING PATTERN

B0	Direct, Bottom connection
B1	Wall/Surface/Projection mounting, Bottom connection
B2	2" Pipe/Yoke mounting, Bottom connection
B6	Bottom connection with Anti-Vibration spring
B9	Every Angle mounting, Direct Bottom connection
R0	Centre Back connection
R1	Every Angle mounting, Centre Back connection
L0	Lower, Back connection
L1	Panel/Front flange mounting, Lower Back connection
L2	Panel/bracket mounting, Lower Back connection

B0

4. STEM DIAMETER

M60	6.0 mm	I14	¼" (6.35 mm)
M80	8.0 mm	M95	9.5 mm
M10	10 mm	M12	12 mm

M60

5. INGRESS PROTECTION

ER	IP 65	ES	IP 66
ET	IP 67		

ER

6. STEM LENGTH

XXXX	Up to 2000 mm (Confirm factory before ordering)
-------------	--

300

7. PROCESS CONNECTION TYPE

KX	Fixed connection
KW	Adjustable connection
BW	Swivel / Revolving connection

KW

8. PROCESS CONNECTION

14N	½" NPT (M)	14B	½" BSP (M)
12N	¼" NPT (M) ⁵	12B	¼" BSP (M) ⁵
14M	M20 X 1.5 mm (M)	13B	3/8" BSP (M) ⁶

14N

9. ASSEMBLY

B8	Direct (Stem type)
B9	Remote (Capillary type)

B8

10. CAPILLARY

OU	AISI 304SS	OV	AISI 316 SS
-----------	------------	-----------	-------------

XX

11. ARMOUR

OX	AISI 304SS	OY	AISI 316 SS
OZ	PVC (Ambient max. 60°C)		

XX

12. REMOTE MOUNTING LENGTH

XXXXX	250 mm up to 10,000 mm
XXXXX	10,000 mm up to 25,000 mm

XXXXX

13. OTHER OPTIONS

BA	Case & Ring in AISI 316 SS (B0)
BB	Case & Ring in AISI 316 SS (B1)
BC	Case & Ring in AISI 316 SS (B2)
BG	Case & Ring in AISI 316 SS (R0)
BH	Case & Ring in AISI 316 SS (R1)
BK	Case & Ring in AISI 316 SS (L0)
BL	Case & Ring in AISI 316 SS (L1)
BM	Case & Ring in AISI 316 SS (L2)
HU	Case & Ring in AISI 316 SS (B6)
HV	Case & Ring in AISI 316 SS (B9)
E9	Helium gas filled system
GC	Shatterproof safety glass
GM	Dampened movement
GW	Maximum reading pointer
OA	Dampening liquid, silicon oil (200°C)
OL	Dampening liquid, silicon oil (350°C)
RA	Rubber parts, Viton
RN	Rubber parts, NBR
TA	5 - point factory calibration certificate
TM	Material test certificate 2.2
XF	SS tag plate, AISI 304 SS
XG	SS tag plate, AISI 316 SS
XT	Dial tag marking
XR	Custom designed dial
EG	Dampening liquid, glycerin (65°C)

XX

Ordering Example : T701-04-C16-B0-M60-ER-300-KW-14N-B8

NOTES

- For other ranges, connections, please contact factory.
- Equivalent scales available in °F, °C/°F, °F/°C.
- Option "Case & Ring in AISI 316 SS" is applicable for DN100 & DN150 only.
- While selecting capillary, Bottom connections are supplied with wall mounting flange & Back connection are with Panel / front flange.
- 1/4" connections are available up to 1/4" (6.35 mm) stem diameter only.
- 3/8" connections are available up to 10 mm stem diameter only.