

REFLEX / TRANSPARENT FLAT GLASS LEVEL GAUGE 'RFG / TFG'

Reflex / Transparent Glass Level Gauges are designed for safe & positive visual indication of liquid level in vessels under high pressure & temperature conditions. **Reflex Flat Glass** has precision molded prismatic grooves cut on inner surface, which comes in contact with liquid. Light striking on glass portion covered by liquid is refracted (absorbed) making this portion appear BLACK, whereas glass portion covering vapour space reflects light, making it appear SILVERY-WHITE. Thus, a sharp clear line marks the liquid, eliminating all possibilities of errors in reading. **Transparent Flat Glass** is a clear glass with smooth finish, used for visual level indication of dirty, viscous liquids or liquid / liquid interface.

Construction:

Reflex (Fig.1): The liquid chamber (01) is formed by one piece metal body, reflex gauge glass (08), sealing gasket (04), cushion (05) and cover plate (02) all held together by 'U'-bolts & nuts (09). The gauge glass sandwiched between the gasket & cushion is placed on front side for viewing of liquid level & held in the recesses machined in the body and cover plate. This ensures leak proof assembly, which prevents gasket/cushion slippages and avoids glass to metal contact. The glass section comes in lengths from 190mm to 340mm and as many as 5 can be fitted in a single gauge assembly. Longer CC distance can be provided by coupling two gauge assemblies through a flanged coupler or the level gauges can be installed in staggered manner. The level gauge is usually provided with shut-off valves at either ends, to isolate the gauge in the event of glass breakage or replacement.

Transparent (Fig. 2): The construction is similar to Reflex except that the liquid chamber (01) is formed by one piece metal body and a pair of transparent gauge glass on its front & rear side.

Specifications:

Gauge classification x Test pressure	: Low Pressure x 30 kg/cm ² , Medium Pressure x 85 kg/cm ² , High Pressure x 165 kg/cm ² , Very High pressure x 210 kg/cm ²
Gauge glass	: Tempered soda ash/ borosilicate (30 W x 17 Th)/ Tempered borosilicate (34 W x 17 Th)
Sealing/cushion gasket	: CAF, CNAF, PTFE, Graphoil reinforced SS304 or SS316
Body (liquid chamber)	: CS, CS ASTM A105, SS304/316/316L (RFG/TFG) PP (CS reinforced) or Rubber lined CS (RFG)
Cover plate	: CS ASTM A105, SS304/316 or FRP
Chamber connection	: ½" NPT (F)
Bolts x nuts	: CS x CS ; A193 Gr.B8 x A194 Gr.8 (SS304); A194 Gr.B8M x A194 Gr.8M (SS316) A193 Gr.B7 x A194 Gr.2H
Gauge connection	: Straight through (top- bottom); Hook up (side-side)
Process connection	: Flanges or screwed (male shank, union or spherical union)
Process conn. orientation:	: Rear-rear, left-left, right-right, vertical-vertical
Isolating valves	: Offset needle valve x auto ball check x screwed bonnet (85 kg/cm ²) / bolted bonnet (OS & Y) 210 kg/cm ²
Vent & drain (Metallic): (PP)	: ½" NPT plugs or valves (ball, globe or gate) ½" BSP plugs or ball valves
Calibrated scale	: SS304
Max. temperature	: 70 °C (pp), 400 °C (metallic),
CC distance (Metallic): (PP)	: 330 to 2280 mm (straight- through) 170 to 2120 mm (hook up) 320 to 1600 mm (straight- through)
Special features	:
Frost Free	: An extended Perspex plate fitted on gauge glass
Jacketing	: ½" SS pipe with condensate drain valve
Illuminator	: Cast Al. enclosure IP65 or Exd Gr. IIB or IIC T6, IP65 or ATEX IIC, T6 holding LED bulb (supply- 80 to 250 VAC)

NB : MOC of isolation valves & process connections will be same as that of liquid chamber

REFLEX-RFG



TRANSPARENT-TFG



Fig.1
REFLEX

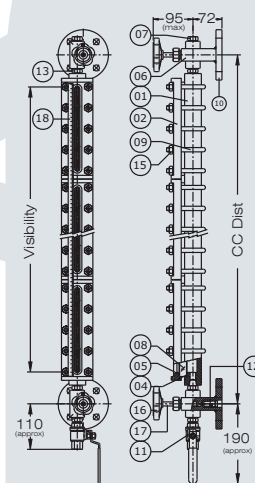
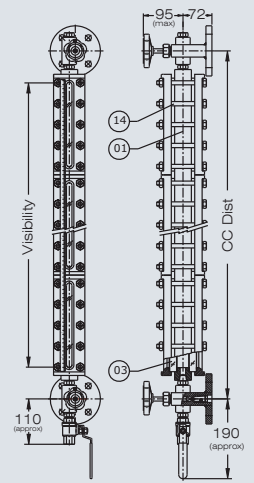

Fig.2
TRANSPARENT



- | | |
|-------------------------|------------------------|
| 01) Liquid Chamber | 10) Process Connection |
| 02) Cover Plate | 11) Drain Valve (B.V.) |
| 03) Gauge (Transparent) | 12) Auto Ball Check |
| 04) Gasket | 13) Adapter |
| 05) Cushion | 14) Studs |
| 06) Isolating Valve | 15) Nuts & Bolts |
| 07) Vent Plug | 16) Hand Wheel |
| 08) Gauge (Reflex) | 17) Valve Needle |
| 09) 'U' Bolts | 18) Cal Scale |

Reflex

Fig. 3

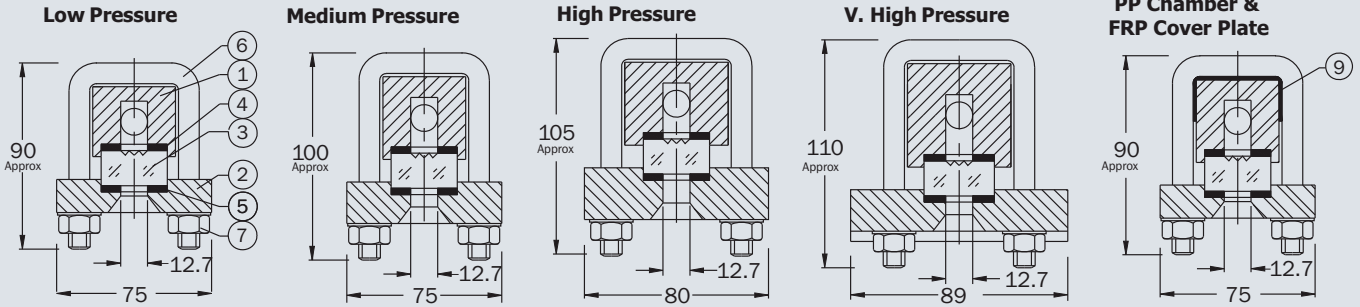

Transparent

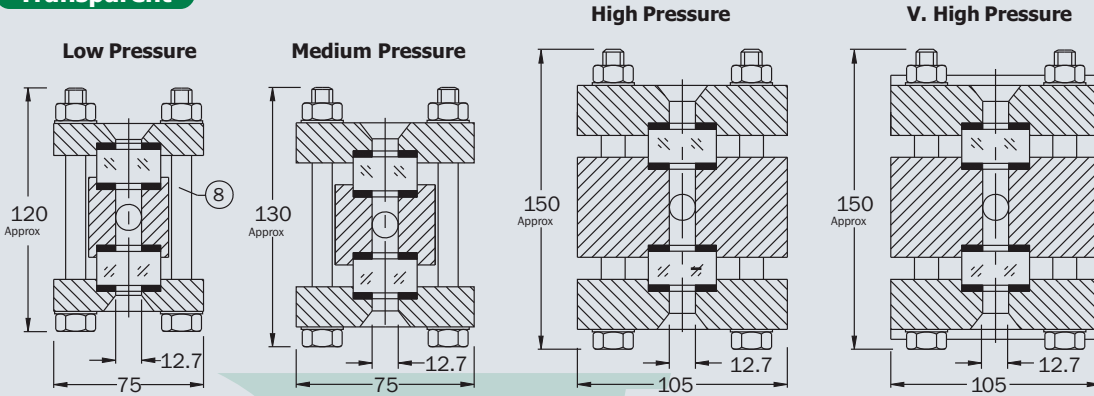

- 1) Liquid chamber
- 2) Cover plate
- 3) Gauge glass
- 4) Gasket
- 5) Cushion
- 6) `U` bolt
- 7) Nuts & washers
- 8) Stud bolt
- 9) CS reinforced

Exploded view

Fig. 4

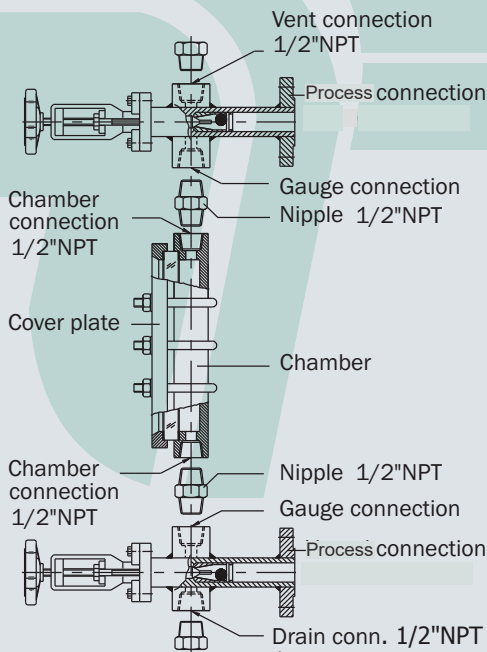

* Mica shield cannot be provided with reflex glass as it will prevent refraction of light

Gauge Connection & Isolating Valve

Fig. 5

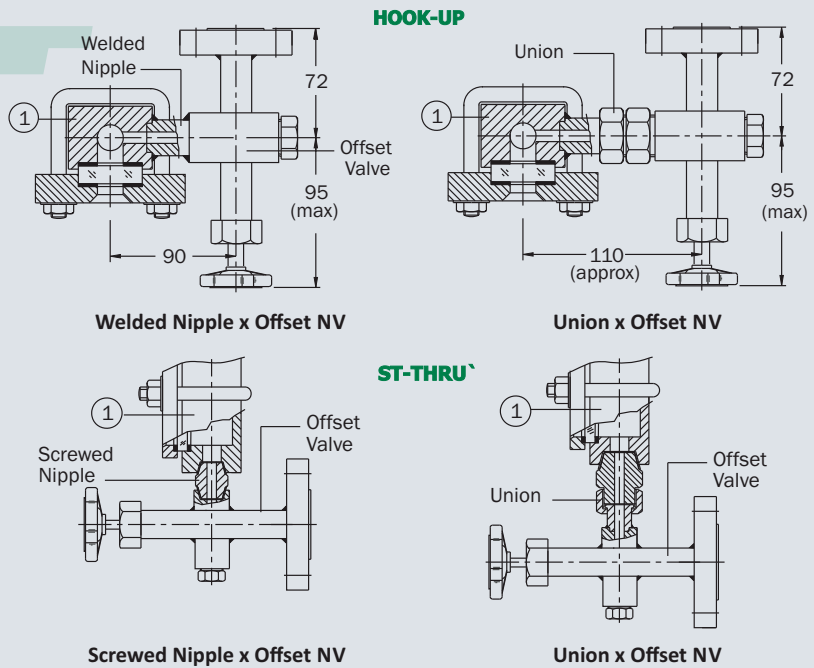

Function of Auto Ball Check

Autoball check facility is provided to prevent "liquid loss" from vessel during breakage of gauge glass. It consists of a capsule located within the gauge 'neck' and contains a 'ball' which moves freely along its inner race between the stopper & orifice. During breakage, the pressure on 'ball' from gauge side will be atmospheric, whereas higher pressure from vessel side ("optg pr + liquid column") will cause the ball to move and block the orifice, to minimize liquid loss.

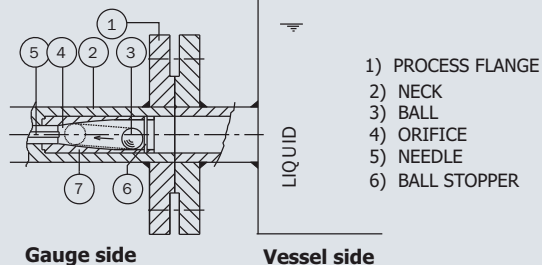

Fig. 6

Isolating Valve Bonnet

Screwed Bonnet

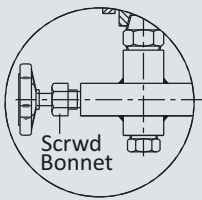
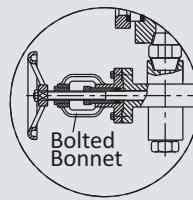

Fig. 7

Bolted Bonnet
Outside Screw



Process (Vessel) Connections

- 1) Flanged
- 2) Male Screwed Shank
- 3) Male Screwed Union
- 4) Male Sph. Union

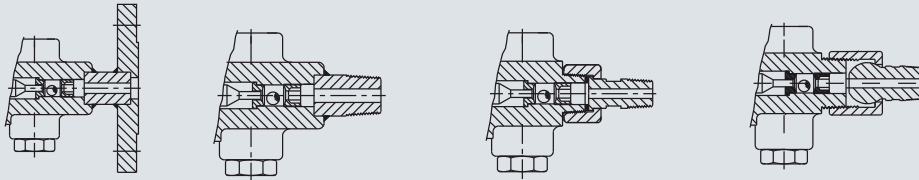
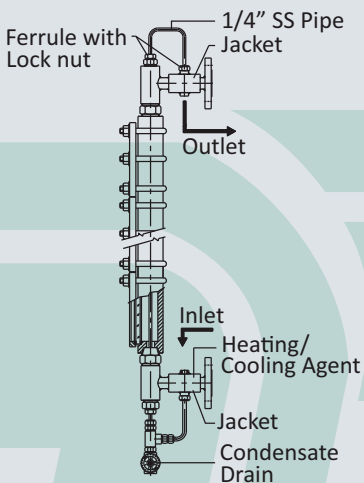

Fig. 8

Jacketing

Fig. 9



Is employed for heating/cooling of process liquid at temperature other than amb temperature, to prevent its solidification. Heating is done thru` hot water / steam and cooling thru` a refrigerant like freon, propane, or ammonia, which pass internally thru` a SS pipe, gauge chamber to come in direct contact with process liquid.

Illuminator

Fig. 10

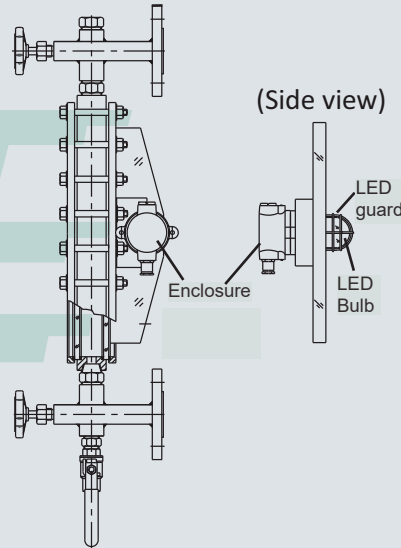

Illuminates poorly lit areas to improve visibility & indication

Fig. 12

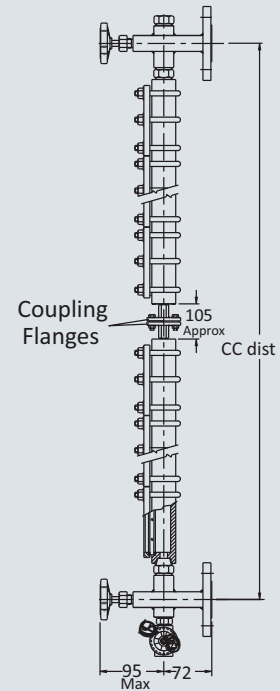

Long CC. Distance with 2-Chambers

Fig. 13

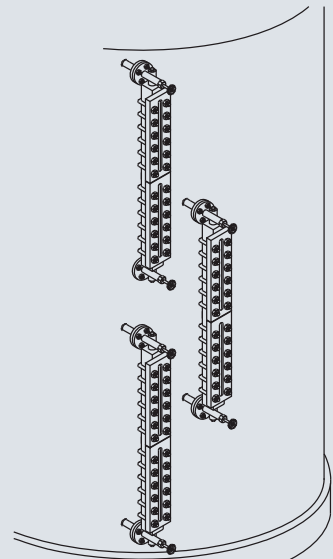

For continuous visibility without dead band in case of large vertical tanks

Staggered Installation

Frost Free Extension (Sectional View)

Fig. 11

Is employed for visual indication of liquid at low temperature. Perspex plate extension is fitted on to the gauge glass to prevent frost formation on the outer surface of gauge glass to improve clarity of visual indication of liquid.

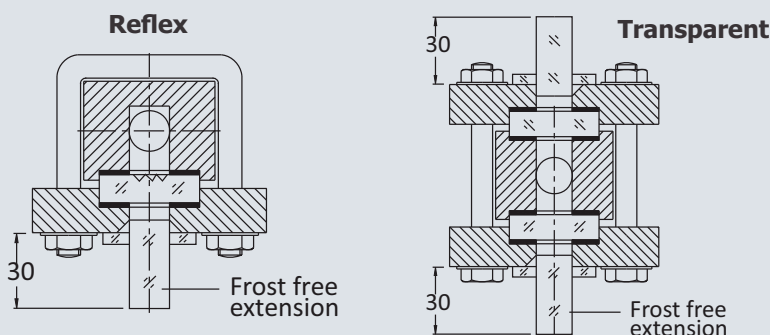

Orientation of Process Conn.

Fig. 14

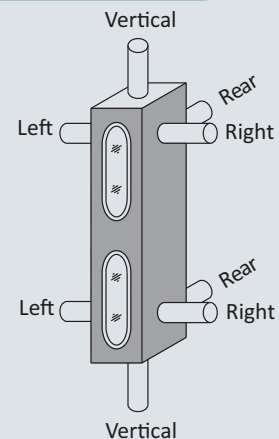

Note : RFG (hook-up & straight thru) and TFG (straight thru) available in above orientations. **TFG (hook-up) not provided in Left x Left and Right x Right orientation.**

Gauge Classification	Body MOC	Gauge Glass MOC	Gauge Glass Size (mm)	NON STEAM SERVICES						STEAM SERVICES					
				REFLEX			TRANSPARENT			REFLEX			TRANSPARENT with Mica Shield		
				Max Temp °C	Max Optq. Pressure (kg/cm ²)	Max Test Pressure (kg/cm ²) at amb temp	Max Temp °C	Max Optq. Pressure (kg/cm ²)	Max Test Pressure (kg/cm ²) at amb temp	Max Temp °C	Max Optq. Pressure (kg/cm ²)	Max Test Pressure (kg/cm ²) at amb temp	Max Temp °C	Max Optq. Pressure (kg/cm ²)	Max Test Pressure (kg/cm ²) at amb temp
Low	PP	Soda Ash	30W x 17T	80	1.5	3	NA	NA	NA	--	--	--	--	--	--
	Metallic	Soda Ash	30W x 17T	100	20	30	100	20	30	--	--	--	--	--	--
	Metallic	Borosilicate	30W x 17T	400	20	30	400	20	30	--	--	--	--	--	--
Medium	Metallic	Borosilicate	30W x 17T	400	56	85	400	56	85	243	32	64	243	35	70
High	Metallic	Borosilicate	30W x 17T	400	110	165	400	110	165	--	--	--	300	70	140
Very High	Metallic	Borosilicate	30W x 17T	400	140	210	--	--	--	--	--	--	300	80	160

Fig 15

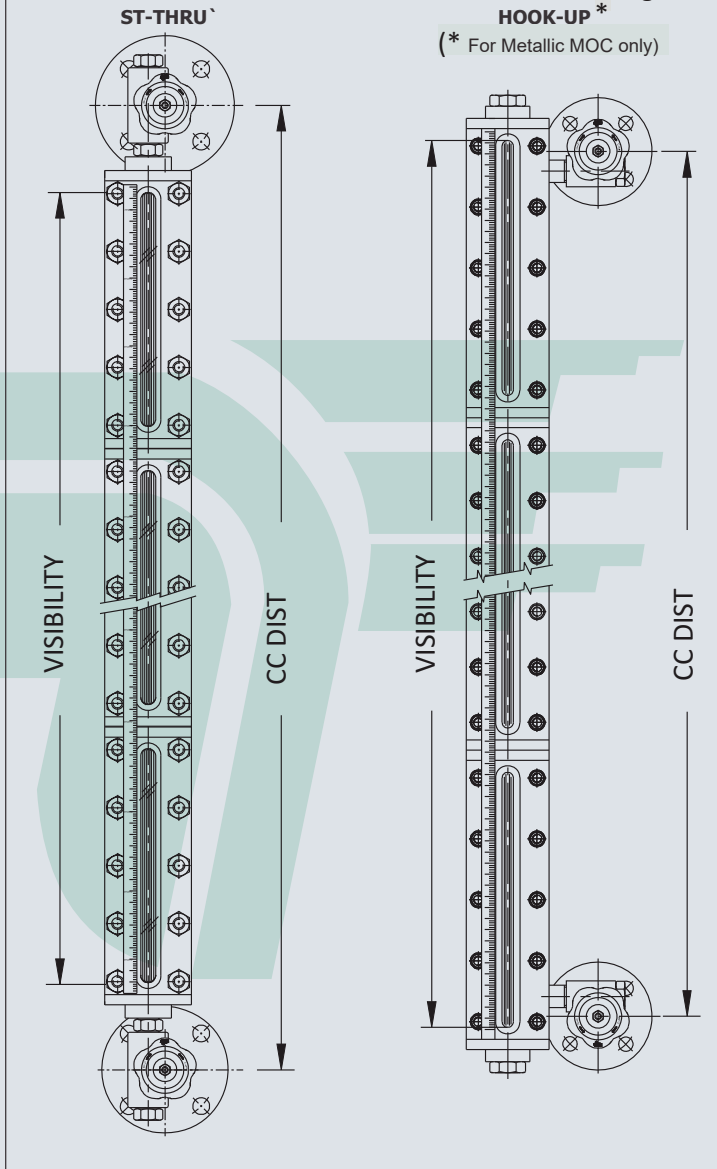

Ordering Information

Specify Model No., Liquid, CC Dist, Optg. Temperature & Pressure

Pune Techtrol Pvt Ltd [CIN : U31909PN1991PTC063403]

Address : S-18, MIDC, Bhosari, Pune - 411026. India

✉ ho@punetechtrol.com ☎ +91-20-66342900 🌐 www.punetechtrol.com

Works : J-52/7, MIDC, Bhosari, Pune - 411026. India ☎ +91-20-67313600

Custom built specs./options available on demand. We reserve the right to modify design and specifications without prior notice.

ASME 300 # RF Flange with Screwed Union	N			
ASME 600 # RF Flange with Screwed Union	P			
ASME 150 # RF Flange with Spherical Union (<i>upto high pressure</i>)	Q			
ASME 300 # RF Flange with Spherical Union (<i>upto high pressure</i>)	R			
ASME 600 # RF Flange with Spherical Union (<i>upto high pressure</i>)	S			
Others	O			
12. Process Connection Orientation				
Rear x Rear	B			
Left x Left (<i>RFG or with Straight Thru Conn. in TFG</i>)	L			
Right x Right (<i>RFG or with Straight Thru Conn. in TFG</i>)	R			
Others	O			
13. Bolts x Nuts				
CS x CS (<i>upto medium pressure</i>)		1		
A 193 Gr. B7 x A 194 Gr 2H (<i>upto very high pressure</i>)		2		
A193 Gr B8 x A194 Gr 8 (SS304) (<i>upto medium pressure</i>)		3		
A193 B8M x A194 Gr 8M (SS316) (<i>upto medium pressure</i>)		4		
Others		O		
14. Special Features				
Without			W	
Frost Free Extension			F	
Jacketing (<i>for single length gauge only</i>)			J	
Illuminator IP65 (<i>recommended for TFG</i>)			X	
Illuminator Ex d Gr IIB T6, IP65 (<i>recommended for TFG</i>)			Y	
Illuminator Ex d Gr IIC T6, IP65 (<i>recommended for TFG</i>)			Z	
Illuminator ATEX Ex d Gr IIC T6, IP65 (<i>recommended for TFG</i>)			V	
Others			O	
15. Calibrated Scale MOC				
Without				W
SS304 scale in mm (LC= 5 mm)				1
SS304 scale in cm (LC= 0.5 cm)				2
SS304 scale in inches (LC= ¼")				3
Others				O